

TEXWRAP[®]2219MP

A DIVISION OF STORK FABRICATORS, INC. / MADE IN U.S.A.

L-BAR MULTI-PACKER

Features, Functions & Benefits

- Programmable transfer into tunnel
- Allen Bradley controls
- Swivel mount touchscreen control with setup helper.
- Variable speed belts: 20-100 FPM
- Touch screen product library
- Independent conveyors allow relaxed film at Cross Seal
- Touchscreen programmable servo pusher
- Inverter duty AC motors (no DC)
- Closing conveyor for small pack patterns
- Knife edge exit conveyor for smooth transfer into tunnel
- Fully automatic product indexing & package length adjustment to accommodate most package configurations.
- Thermostatically controlled hot knife seal systems
- Calibrated package height and width adjustments
- Lay-on film cradle with power film unwind
- Self contained film scrap wind-up system with adjustable tension
- Pin perf system for air evacuation
- Tubular steel construction with powder coat finish
- Automatic dwell time compensator
- Scrap break alarm
- Adjustable soft/start with controlled braking



AVERO

PACKAGING CORPORATION

Flexible Packaging – Machinery & Materials

888 East Belvidere Rd., Unit 206, Grayslake, IL 60030
Phone: (847) 231-6100 Fax: (847) 231-6101



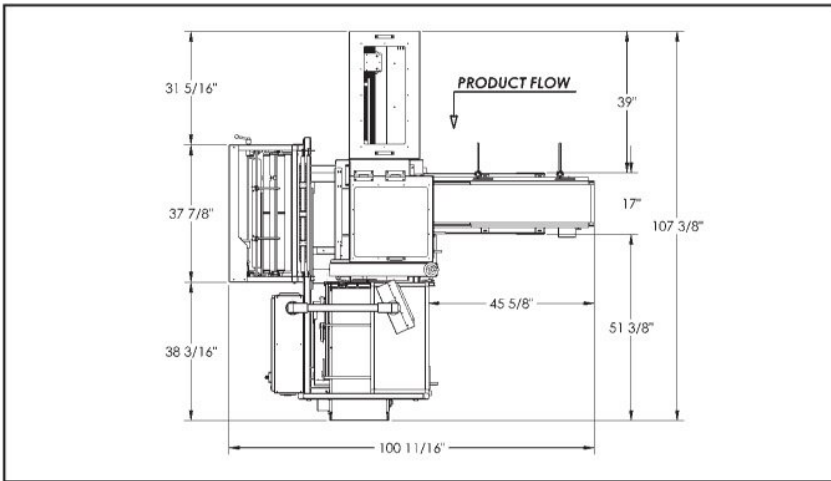

SPECIFICATIONS	2219MP
MAXIMUM PKG SIZE	19"L x 15-1/2"W x 7"H
MINIMUM PKG SIZE	4"L x 2-3/4"W (standard) 2"L x 2-3/4"W (with closing conv.)
FILM WIDTH	Max. 28" CF/ Min. 6" CF
ELECTRICAL	220 Volts AC, 20 amps
AIR REQUIREMENTS	80 PSI, 5 CFM
CONVEYOR HEIGHT	Adj. From 29.5" to 35.5" H
FILM SPEED RANGE	20-100 FPM
MACHINE CONTROLS	Allen Bradley
CONTROL PANEL	Easy Access Swivel Mounted

LOW FILM STAND

The 28" low film stand comes standard for easy loading.

PUSHER BAR

Product slides onto the infeed conveyor and is grouped together by the pusher conveyor.

TYPICAL PRODUCT

The 2219MP can accommodate several product configurations.

ADD OTHER TEXWRAP EQUIPMENT FOR A COMPLETE SYSTEM:			
INFEEDS: Texwrap produces a full range of infeed conveyors from simple belt, lug, and flight bar to Servo placement systems that will enhance the operation of the 1809SS Wrapper.	Belted Conveyor 	Flighted Conveyor 	Flightbar Conveyor
TUNNELS: Cool-Touch Texwrap Tunnels offer the proper balance between cost, versatility and durability. These tunnels are designed for multiple shifts 24/7 operation. Optional lighted window on all models.	Single Tunnel 	Double Tunnel 	Tunnel Window